

INSTRUCTION MANUAL

BS-321AS

**Semi - Automatic Swivel Head-Dual Mitre
Metal Cutting Band Saw (415V)
510 x 260mm (W x H) Rectangle**



B034A



WARNING

General Machinery Safety Instructions

Machinery House
requires you to read this entire Manual before using this machine.

- 1. Read the entire Manual before starting machinery.** Machinery may cause serious injury if not correctly used.
- 2. Always use correct hearing protection when operating machinery.** Machinery noise may cause permanent hearing damage.
- 3. Machinery must never be used when tired, or under the influence of drugs or alcohol.** When running machinery you must be alert at all times.
- 4. Wear correct Clothing.** At all times remove all loose clothing, necklaces, rings, jewelry, etc. Long hair must be contained in a hair net. Non-slip protective footwear must be worn.
- 5. Always wear correct respirators around fumes or dust when operating machinery.** Machinery fumes & dust can cause serious respiratory illness. Dust extractors must be used where applicable.
- 6. Always wear correct safety glasses.** When machining you must use the correct eye protection to prevent injuring your eyes.
- 7. Keep work clean and make sure you have good lighting.** Cluttered and dark shadows may cause accidents.
- 8. Personnel must be properly trained or well supervised when operating machinery.** Make sure you have clear and safe understanding of the machine you are operating.
- 9. Keep children and visitors away.** Make sure children and visitors are at a safe distance for you work area.
- 10. Keep your workshop childproof.** Use padlocks, Turn off master power switches and remove start switch keys.
- 11. Never leave machine unattended.** Turn power off and wait till machine has come to a complete stop before leaving the machine unattended.
- 12. Make a safe working environment.** Do not use machine in a damp, wet area, or where flammable or noxious fumes may exist.
- 13. Disconnect main power before service machine.** Make sure power switch is in the off position before re-connecting.
- 14. Use correct amperage extension cords.** Undersized extension cords overheat and lose power. Replace extension cords if they become damaged.
- 15. Keep machine well maintained.** Keep blades sharp and clean for best and safest performance. Follow instructions when lubricating and changing accessories.
- 16. Keep machine well guarded.** Make sure guards on machine are in place and are all working correctly.
- 17. Do not overreach.** Keep proper footing and balance at all times.
- 18. Secure workpiece.** Use clamps or a vice to hold the workpiece where practical. Keeping the workpiece secure will free up your hand to operate the machine and will protect hand from injury.
- 19. Check machine over before operating.** Check machine for damaged parts, loose bolts, Keys and wrenches left on machine and any other conditions that may effect the machines operation. Repair and replace damaged parts.
- 20. Use recommended accessories.** Refer to instruction manual or ask correct service officer when using accessories. The use of improper accessories may cause the risk of injury.
- 21. Do not force machinery.** Work at the speed and capacity at which the machine or accessory was designed.
- 22. Use correct lifting practice.** Always use the correct lifting methods when using machinery. Incorrect lifting methods can cause serious injury.
- 23. Lock mobile bases.** Make sure any mobile bases are locked before using machine.
- 24. Allergic reactions.** Certain metal shavings and cutting fluids may cause an allergic reaction in people and animals, especially when cutting as the fumes can be inhaled. Make sure you know what type of metal and cutting fluid you will be exposed to and how to avoid contamination.
- 25. Call for help.** If at any time you experience difficulties, stop the machine and call you nearest branch service department for help.



Metal Cutting Bandsaw Safety Instructions

Machinery House
requires you to read this entire Manual before using this machine.

- 1. Maintenance.** Make sure the bandsaw is turned off and disconnect from the main power supply and make sure all moving parts have come to a complete stop before any inspection, adjustment or maintenance is carried out.
- 2. Bandsaw Condition.** Bandsaw must be maintained for a proper working condition. Never operate a bandsaw that has damaged or worn parts. Scheduled routine maintenance should be performed on a scheduled basis.
- 3. Blade Condition.** Never operate a bandsaw with a dull, cracked or badly worn blade. Before using a bandsaw inspect blades for missing teeth and cracks.
- 4. Replacing Blade.** Make sure teeth are facing the correct direction. Wear gloves to protect hands and wear safety glasses to protect your eyes.
- 5. Hand Hazard.** Keep hands and fingers clear from the line of cut of the blade and offcuts workpieces. Hands can be crushed in vice or from falling machine components and cut by the blade.
- 6. Leaving a bandsaw Unattended.** Always turn the bandsaw off and make sure all moving parts have come to a complete stop before leaving the bandsaw. Do not leave bandsaw running unattended for any reason.
- 7. Avoiding Entanglement.** Blade guard must be used at all times. Remove loose clothing, belts, or jewelry items. Never wear gloves while machine is in operation. Tie up long hair and use the correct hair nets to avoid any entanglement with the bandsaw moving parts.
- 8. Understand the machines controls.** Make sure you understand the use and operation of all controls.
- 9. Power outage.** In the event of a power failure during use of the bandsaw, turn off all switches to avoid possible sudden start up once power is restored.
- 10. Work area hazards.** Keep the area around the bandsaw clean from oil, tools, chips. Pay attention to other persons in the area and know what is going on around the area to ensure unintended accidents.
- 11. Workpiece Handling.** Workpieces must be supported with table, vice, roller conveyor/stands, or other support fixtures. Unsupported workpieces may cause the machine to tip over and fall. Flag long pieces of material to avoid tripping hazards. Never hold a workpiece with your hands during the cut process.
- 12. Hearing protection and hazards.** Always wear hearing protection as noise generated from bandsaw blade and workpiece vibration, material handling, and power transmission can cause permanent hearing loss over time.
- 13. Hot surfaces.** Workpieces, machine surfaces and chips become hot due to friction and can burn you.
- 14. Starting position.** Never turn the bandsaw on when the blade is resting on the workpiece.
- 15. Guards.** Do not operate bandsaw without the blade guard in place or with the doors open.
- 16. Call for help.** If at any time you experience difficulties, stop the machine and call your nearest branch service department for help.

PLANT SAFETY PROGRAM

NEW MACHINERY HAZARD IDENTIFICATION, ASSESSMENT & CONTROL

Metal Cutting Bandsaw

Developed in Co-operation Between A.W.I.S.A and Australia Chamber of Manufactures
This program is based upon the Safe Work Australia, Code of Practice - Managing Risks of Plant in the Workplace (WHSA 2011 No10)

Item No.	Hazard Identification	Hazard Assessment	Risk Control Strategies <small>(Recommended for Purchase / Buyer / User)</small>
A	ENTANGLEMENT	HIGH	Eliminate, avoid loose clothing / Long hair etc.
B	CRUSHING	LOW	Secure & support Long / heavy material
C	CUTTING, STABBING, PUNCTURING	MEDIUM	Blade guards should always be in the closed position before starting machine. Blade guide system should be adjusted to suit material width. Wear gloves when changing blades. Isolate main power switch before changing blade, cleaning or adjusting. If blade breaks do not open door until both wheels have stopped. Check blade tracking before starting.
D	SHEARING	MEDIUM	Make sure all guards are secured shut when machine is on. Isolate power to machine prior to changing belts or maintenance.
F	STRIKING	LOW	Support long heavy jobs and stand clear of offcuts. Stand clear of machine when in operation. Remove all loose objects around moving parts. Wear safety glasses
H	ELECTRICAL	MEDIUM	All electrical enclosures should only be opened with a tool that is not to be kept with the machine. Machine should be installed & checked by a Licensed Electrician.
O	OTHER HAZARDS, NOISE.	LOW	Wear hearing protection as required.
Plant Safety Program to be read in conjunction with manufactures instructions			



www.machineryhouse.com.au



www.machineryhouse.co.nz

Authorised and signed by:
Safety officer:

Manager:

Revised Date: 12th March 2012

TABLE OF CONTENTS

1	ACCIDENT PREVENTION AND SAFETY REGULATION.....	1
	1.1 Advice for the operator.....	1
	1.2 The electrical equipment according to European Standard" CENELEC EN 60204-1".....	1
	1.3 Warning labels	1
	1.4 Emergencies according to European Standard "CENELEC EN 60204-1".....	1
2	MACHINE TRANSPORTATION AND INSTALLATION.....	2
	2.1 Machine dimensions	2
	2.2 Transporting the machine	2
	2.3 Minimum requirements for housing the machine.....	2
	2.4 Installing the rear coolant return tray	2
	2.5 Install the outlet tray, length stop device and mobile coolant trays.	3
	2.6 Securing to foundation	3
	2.7 Leveling the machine	3
	2.8 Deactivation of machine.....	3
3	DESCRIPTION OF MACHINE PARTS.....	4
	3.1 Control panel.....	4
	3.2 The saw bow	4
	3.3 The vise system	4
	3.4 The base	4
	3.5 Chip tray.....	4
	3.6 Blade broken micro switch	4
	3.7 Chip brush.....	5
	3.8 Open Blade Cover Safety Device	5
	3.9 Speed change dial	5
	3.10 Blade angle scale.....	5
	3.11 Attached coolant device	5
4	SET UP AND PRE-OPERATIONS	5
	4.1 Adjusting the tungsten carbide guides.....	5
	4.2 Thrust Roller Adjustment	6
	4.3 Adjusting the cutting precision	6
	4.4 Blade tracking adjustment.....	6
	4.5 Placing the saw blade onto the drive wheel and flywheel.....	6
	4.6 Hydraulic vise pressure (optional).....	7
5	OPERATION PREPARATIONS.....	7
	5.1 Setting the saw blade height.....	7
	5.2 Positioning the vise	7
	5.3 Angle cutting	7
	5.4 Using the vise.....	8
	5.5 Adjusting the blade speed.....	8
	5.6 Changing the transmission belt.....	8
	5.7 Changing the blade	8
	5.8 Laser guide device (optional).....	9
	5.9 Install the vertical press on the vise jaws for bundle cutting (optional).....	9
6	OPERATION CYCLE.....	9
	6.1 Operation cycle	9
	6.2 Stopping or emergency stopping	10
7	ROUTINE AND SPECIAL MAINTENANCE.....	10
	7.1 Daily maintenance.....	10
	7.2 Weekly maintenance.....	10
	7.3 Monthly maintenance.....	10
	7.4 Six-monthly maintenance.....	10
	7.5 Oils for lubricating coolant.....	10
	7.6 Oil disposal.....	10
	7.7 Special maintenance.....	10
	7.8 Changing gear oil.....	10
8	TECHNICAL CHARACTERISTICS.....	11
	8.1 Table of cutting capacity and technical details	11
	8.2 NOISE TESTS	11
9	CONTROL CIRCUIT DIAGRAM	12
10	PART LIST & EXPLOSION DRAWINGS.....	13

1 ACCIDENT PREVENTION AND SAFETY REGULATION

This machine has been designed to comply with national and community accident- prevention regulations. Improper use and/or tampering with the safety devices will relieve the manufacturer of all responsibility.

1.1 Advice for the operator

- Check, the line voltage is the same as the voltage required by the machine's motor.
- Check the efficiency of your electric supply and grounding system; connect the power cable of the machine to the socket and the ground lead (yellow- green in color) to the grounding system.
- When the machine is in suspended mode (or stopped) the blade must not move.
- Only the blade section used for cutting must be kept unprotected. To remove guards to expose more of the cutting blade adjust the blade guides.
- It is forbidden to use the machine without its shields
- Always disconnect the machine from the power socket before blade change or carrying out any maintenance job, even in the case of abnormal machine operation.
- Always wear suitable eye protection.
- Never put your hands or arms into the cutting area while the machine is operating.
- Do not shift the machine while it is cutting.
- Do not wear loose clothing like: shirts with sleeves that are too long, gloves that are too big, bracelets, chains or any other object that could get caught in the machine during operation. Tie back long hair.
- Keep the area free of miscellaneous object; i.e. equipment, tools, etc...
- Perform only one operation at a time. Never have several objects in your hands at the same time. Keep your hands as clean as possible.
- All internal operations, maintenance or repairs, must be performed in a well-lit area or where there is sufficient light from extra sources to avoid the risk of accidents.

1.2 The electrical equipment according to European Standard "CENELEC EN 60204-1"

- The electrical equipment ensures protection against electric shock as a result of direct or indirect contact. The active parts of this equipment are housed in a box to which access is limited by screws that can only be removed with a special tool; the parts are fed with alternating current as low voltage (110V). The equipment is protected against splashes of water and dust.
- Protection of the system against short circuits is ensured by means of rapid fuses and grounding; in the event of a motor overload, protection is provided by a thermal probe.

- In the event of a power cut, the specific start-up button must be reset.
- The machine has been tested in conformity with point 20 of EN 60204

1.3 Warning labels



Replace warning labels if they become obscured or removed.

- Keep hands and other body parts away from a running blade.
- Do not open the blade cover while machine is running.
- Do not store combustible materials near or around machine.
- Always wear approved safety glasses/face shields while using this machine.
- Keep machine guards in place at all times.
- Do not wear gloves.
- Remove loose clothing and confine long hair.
- Keep the work area clean and free miscellaneous objects.

1.4 Emergencies according to European Standard "CENELEC EN 60204-1"

- In the event of incorrect operation or a danger condition, the machine may be stopped immediately by pressing the red mushroom shaped button.

NOTE: Resetting of machine operation after each emergency stop requires resetting the emergency stop button.

2 MACHINE TRANSPORTATION AND INSTALLATION

2.1 Machine dimensions

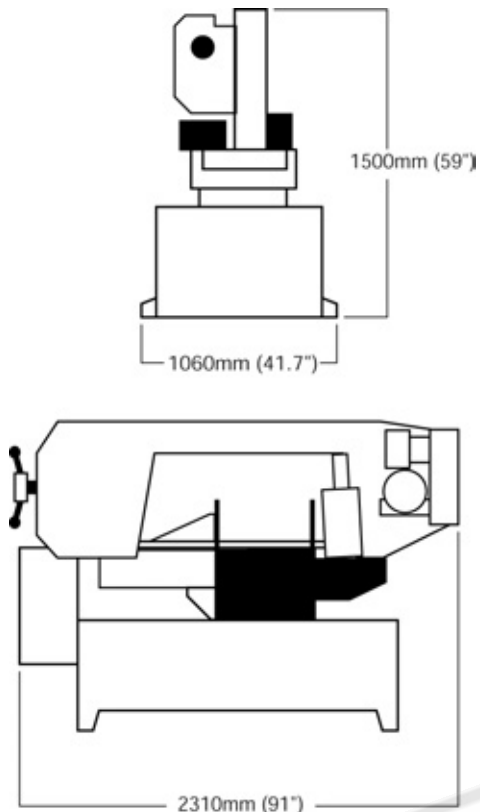

2.2 Transporting the machine

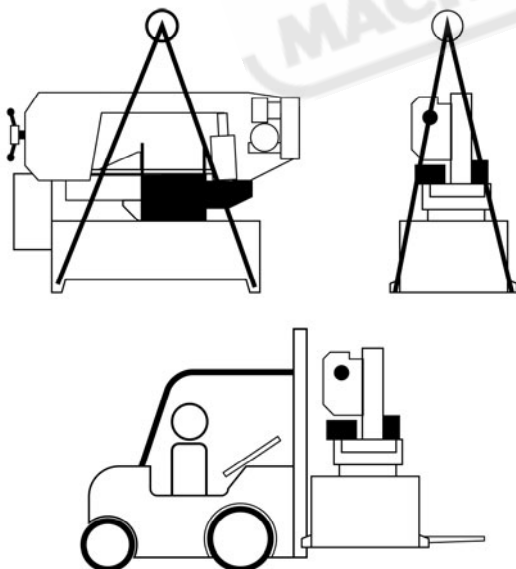

Unpack your machine carefully, and use a crane or forklift to set it in position. If a crane is used to lift the machine, attach the lifting cable carefully to the machine. Sufficient space should be left around the machine to allow safe handling of materials, inspection, and maintenance operations. Take precautions to choose a location that will keep the machine free of vibration and dust caused by other machinery.

2.3 Minimum requirements for housing the machine

- Main voltage and frequency must comply with the machine's motor requirements.
- Environment temperature should fall within (-10°C to + 50 °C).
- Relative humidity cannot be over 90%.

2.4 Installing the rear coolant return tray

The rear coolant-return tray must be installed after the machine is set in place. Install the coolant return trays first.

Installing three channeled L-bracket

Install three channeled L-bracket to the back of the machine stand. Attaching the brackets requires 6 hex head bolt, 6 spring washers, 6 washers, and 6 nuts.

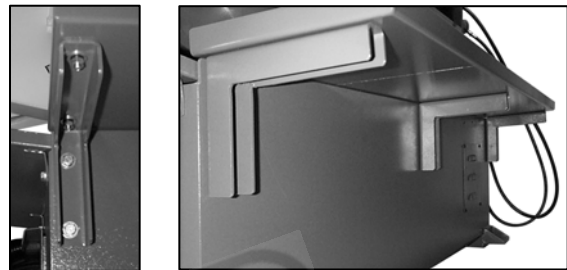

- Place a spring washer and washer on each hex head bolt.
- Face the long side of the bracket up.
- Align the holes of short side of the bracket to the machine panel's holes.
- Place the 2 hex head bolts and their washers through each bracket and machine panel.
- Use a nut on the inside of the machine stand to secure each hex head bolt.

NOTE: Short bracket on the left side

Securing the rear tray

Attaching the trays requires 6 hex head bolt, 6 spring washers, 6 washers, and 6 nuts.

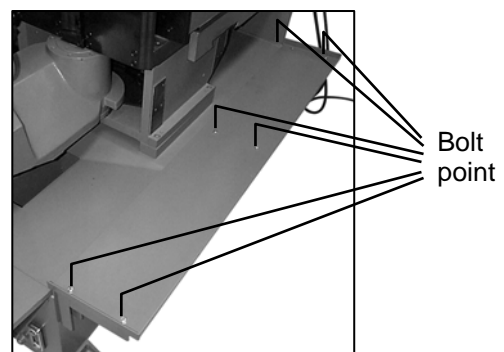

- Arrange the tray rims to facing up and away from the machine.
- Place the rear return tray onto brackets at the back of the machine.
- Align the holes of the rear tray and the six-channeled L-brackets.
- Place 6 hex head bolts through the holes of the trays and brackets.
- Secure each hex head bolts with a washer, spring washer, and hex nut.

2.5 Install the outlet tray, length stop device and mobile coolant trays.

Install the outlet tray and stop bar on to the machine after setting up the machine already as below steps:

1. Assemble the new outlet tray on to the machine by screw in the four screws on the both side as picture. Tighten the four screws after make sure the top of outlet surface same as table.

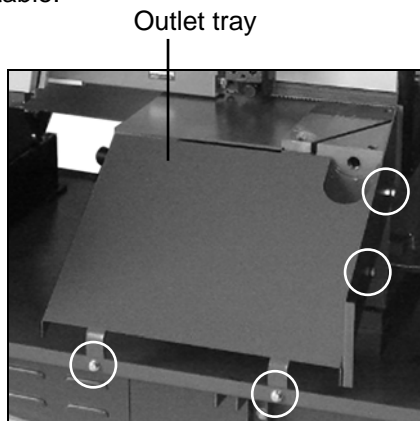

2. Install stop device on to the outlet tray at the right side.



3. Install the mobile cover to the four slots and push it to the right side to secure it.
4. They are two mobile coolant trays can be moved and used in miter cutting on front and rear side to prevent coolant spray on to the floor.

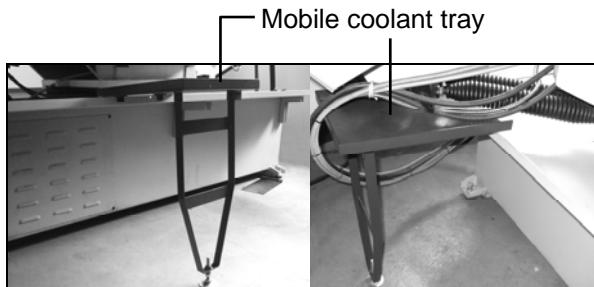

2.6 Securing to foundation

Position the machine on a flat and level foundation of reinforced concrete. Level machine and anchor it to the foundation with anchor bolts. Maintain a minimum distance of 800mm from the

rear of the machine to the wall. Position the anchors using screws and expansion plugs or tie rods sunk in cement.

2.7 Leveling the machine

The operating accuracy of all precision machinery depends on the accuracy of the installation of the machine. Manufacturing tolerance of the machine can only be guaranteed if the machine is firmly and properly installed. Once the machine is lowered on the prepared foundation, machinist levels should be used alternately on the vice slide plates and work feed table, adjust the left to right and front to back level of the machine with leveling bolts.

When leveling left to right level, adjust left side to be approximately 3mm higher than the level of the right side. This will provide proper return of the cutting fluid. After proper leveling of the machine, use anchor bolts to secure to the foundation.

Caution: All leveling bolts should support the weight the machine evenly.

2.8 Deactivation of machine

If the machine is to be out of use for a long period, it is advisable to proceed as follows:

- 1) Disconnect from the power supply
- 2) Loosen the tension on the blade
- 3) Release the bow return spring
- 4) Empty the coolant tank
- 5) Carefully clean and grease the machine
- 6) If necessary, cover the machine.

Dismantling (due to deterioration and/or obsolescence)

As a General Rule,

If the machine is to be permanently demolished and/or scrapped, divide the material to be disposed of according to type and composition, as follows:

- 1) Cast iron or ferrous materials, composed of metal alone, are secondary raw materials, so they may be taken to an iron foundry for re-smelting after having removed the contents (classified in point 3).
- 2) Electrical components, including the cable and electronic material (magnetic cards, etc.), fall within the category of material classified as being assimilated to urban waste according to the laws of your local, state, or federal government, so they may be set aside for collection by the public waste disposal service;
- 3) Old mineral and synthetic and/or mixed oils, emulsified oils and greases are considered hazardous or special refuse, so they must be collected, transported and disposed of at a special waste disposal service.

NOTE: The standards and legislation concerning refuse is in a constant state of evolution, therefore is subject to changes. The user must keep informed of the regulations at the time of disposal as these may differ from those described above.

3 DESCRIPTION OF MACHINE PARTS

3.1 Control panel



- A. Main power indicator light – indicates that main power is active.
- B. Hydraulic flow control valve: turn clockwise to increase bow down rate, counter clock wise to decrease the cutting rate.
- C. Emergency Stop Button – Press to stop all machine functions.
- D. Hydraulic start switch – activates hydraulic power.
- E. Start Blade – press to start cutting cycle-blade start and descend the saw bow.
NOTE: before blade starting, press vise close button (3.1 I) to clamp work piece well.
- F. Stop cutting - Press to stop cutting cycle.
- G. Bow Down Button - Press to descend the saw bow.
- H. Bow Up Button – Press to raise the saw bow.
- I. Vise close Button – press to close the vise.
- J. Vise open Button – press to open the vise.
- K. Coolant start switch – Turn right to activate or turn left to stop coolant flow.
- L. Manual/Auto mode Switch–selects either automatic or manual operation mode.

3.2 The saw bow

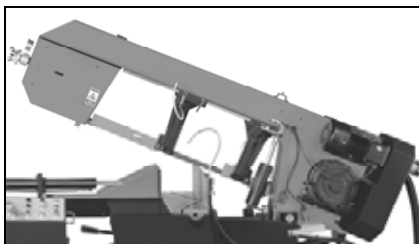

Machine parts consisting of drive members (gear motor, variable speed motor, and flywheels), tightening and guide (blade tightening slide, blade guide blocks) of tool.

3.3 The vise system

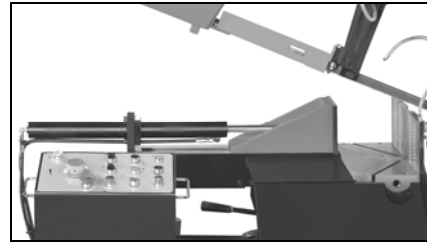

A hydraulic vise is used for clamping work material. Each of the vises has a miter slot, which is good for the right or left side's angle cutting to 60°.

3.4 The base



The base is the structure supporting the saw bow (the bow pivot point and respective blocking system), the vises, and containing chip tray and coolant system.

3.5 Chip tray

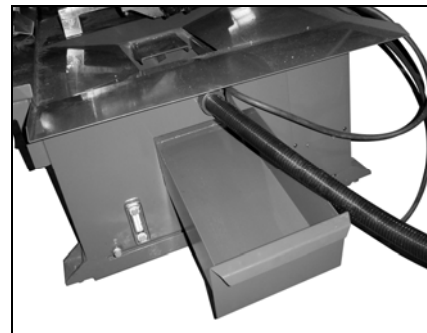

Removable chip tray for capture of chips and debris.

3.6 Blade broken micro switch

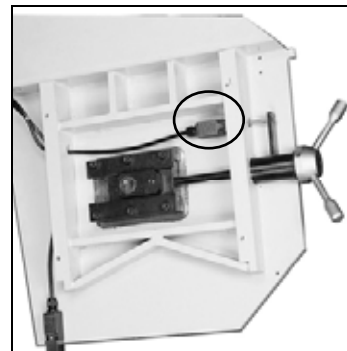

This machine is equipped with automatic power shut-off safety device to prevent any further damage when a blade has been broken. There is a reduction in tension when an adjustment bolt actuates micro switch's plunger. To keep the micro switch in proper contact with the blade's tension. An adjustment of the actuator bolt is required.

3.7 Chip brush



This model has a powered chip brush driven by an axle transfer from the drive motor. The chip brush is designed to clean the blade thus prolonging the life of the blade.

3.8 Open Blade Cover Safety Device

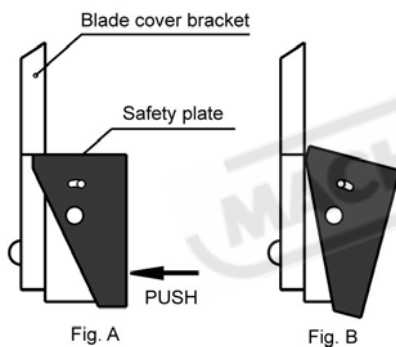

When blade cover is open, close the blade cover as instructed below:

1. Use one hand on the cover handle to hold the blade cover.
2. Use the other hand to push in the safety plate (Fig. A), so the bracket will release (Fig. B).
3. Lower the cover down slowly and carefully.

3.9 Speed change dial



The speed change dial adjusts the variable speed transmission in blade speed. Change only while blade is moving.

This machine has a variable speed transmission using a variable pulley - system. The speed is changed by rotating the speed changer dial to adjust the width of the pulley discs. When compressed, the pulley discs cause the belt to ride the outer edge of pulley discs and changing the speed. The speed must be changed while belt is moving.

3.10 Blade angle scale

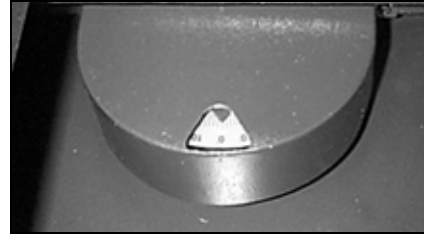

The scale indicates the cutting angle of the blade. The scale has preset stops at every 15°.

3.11 Attached coolant device



An attached coolant device that is screwed on the front vise jaw for supply enough coolant to the cutting material. This device can be unscrewed, and move to the rear vise jaw for easy both side miter cutting.

4 SET UP AND PRE-OPERATIONS

4.1 Adjusting the tungsten carbide guides

The blade is guided by the upper ball bearings, side ball bearings, and tungsten carbide guides.

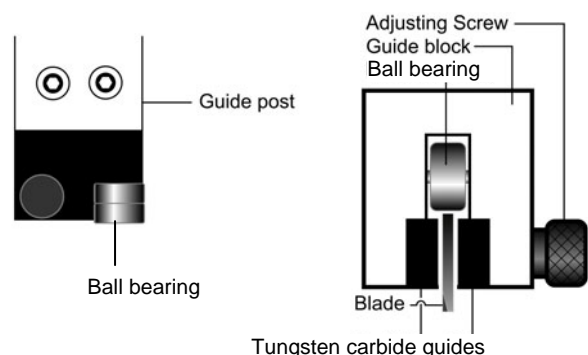

- When ready to cut the work piece, the carbide guide must be adjusted by adjusting the screws to properly compressed blade. The tungsten carbide blades should touch, but not pinch the blade.
- For moving the blade guide posts or changing blade, the tungsten carbide guides should be released by using the adjusting screw.

In case the blade needs to be replaced, make sure to always install 1.3mm thick blade.

4.2 Thrust Roller Adjustment

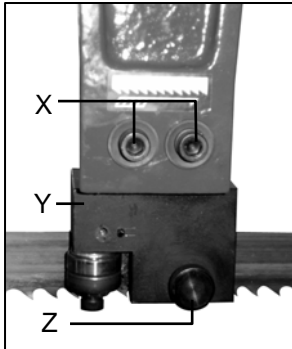

1. Disconnect machine from the power source.
2. Loosen two hex socket cap screws (X)
3. Move guide seat (Y) up or down until a clearance of .003" to .005" between back of blade and thrust roller is obtained.
4. Tighten two hex socket cap screws (X).
5. Repeat for other blade guide assembly.
6. Connect machine to the power source.

4.3 Adjusting the cutting precision

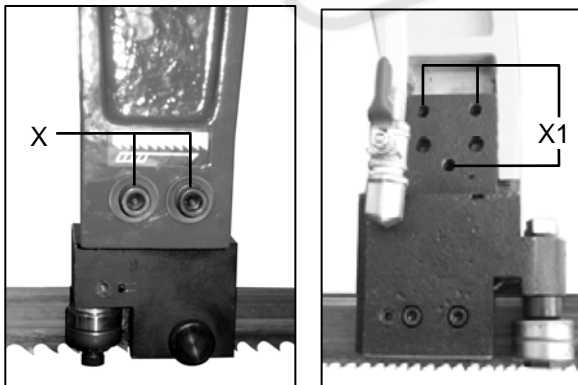

The cutting precision has been set at the factory. This adjustment should only be accomplished by a qualified personnel that are familiar with this type of adjustment.

- Disconnect the machine from power supply.
- Loosen the adjusting bolts (X) slightly, if needed.
- Use the setscrews (X1) to adjust the direction of the guide blocks.
- After adjusting, tighten the adjusting bolts (X).

4.4 Blade tracking adjustment



Caution

Before blade tracking adjustment, make vise clamped and hydraulic flow control valve to zero. Failure to comply may result in injury!

This adjustment must be accomplished by qualified personnel that are familiar with this type of adjustment and the dangers associated with it.

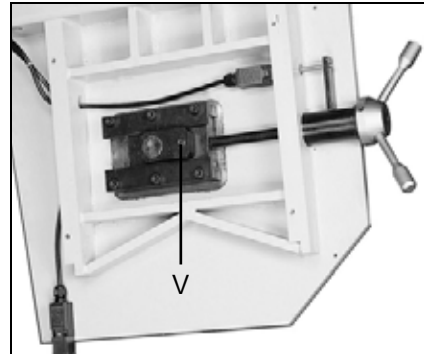

Blade tracking has been set at the factory and has no adjustment required. If a tracking problem occurs, adjust the machine as follows:

- Raise saw arm to the proper position.
- Locate tracking adjustment screw (V) on the front of the saw blade, flywheel side.
- Reduce the blade tension a little.
- Turn the tracking adjustment screw (V) to adjust the saw blade ride.
- Re-tension the blade tension.
- Connect the machine power to run the blade for 1-2 minutes. Then stop the machine operation.
- Remove the blade guides and open covers to check the blade tracking
- Close covers, replace the blade guides and tighten the setscrews.
- If necessary, readjust it again.

4.5 Placing the saw blade onto the drive wheel and flywheel

- Disconnect from power supply
- Remove the blade guards
- Turn the blade tension handle counter-clockwise, to fully loosen the flywheel.
- Open the blade cover and place the saw blade onto the race of the drive wheel and flywheel.
- *Check the cutting direction of the saw blade.
- Insert the saw blade into the rollers of the left and right blade guide.
- The back edge of the saw blade should make contact with the flange of the drive and flywheel; turn clockwise the blade tension handle to tighten the saw blade, until the blade is properly tensioned.
- Replace the blade guards.

- Switch to manual mode, use the blade running switch 3.1 E to check the proper ride of the blade.

4.6 Hydraulic vise pressure (optional)

The hydraulic vise pressure can be monitored and adjusted by a pressure gauge on the base of the machine. The normal pressure is set at 35kgs/cm². This is good for most solid firm materials. For softer, hollow, or pipe materials reduce the pressure to over 25kgs/cm². Other materials may require different clamping force. The clamping pressure may be adjusted by a knob at the base of the pressure gauge assembly.

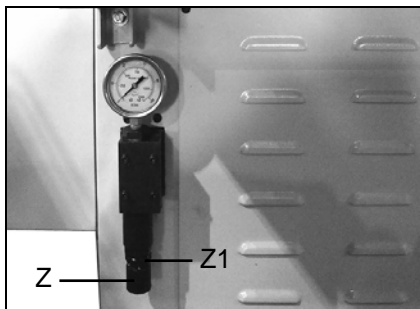

- Start by pressing the vise close switch (3.1 I) continuously in manual mode to have the vise clamp onto a work piece.
- Next, unlock the fluted knob (Z) by releasing fluted lock nut (Z1).
- Turn the fluted knob (Z) counterclockwise to decrease the pressure, clockwise to increase the vise pressure.
- Lock the fluted nut (Z1) after adjustment.

5 OPERATION PREPARATIONS

5.1 Setting the saw blade height

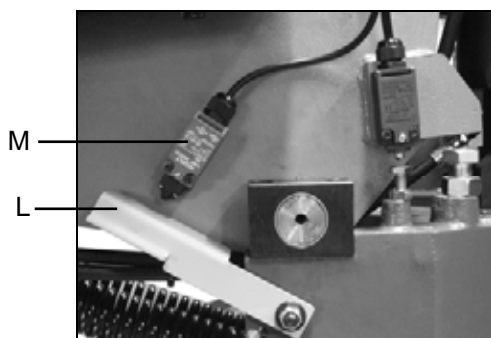

Start the hydraulic power and Arise saw bow to the properly height. Adjust contactor (L) to touch upper limited saw bow height micro switch (M) manually.

5.2 Positioning the vise

When cutting angles, the relocation of the vise is necessary to prevent the blade from cutting the hydraulic vise.

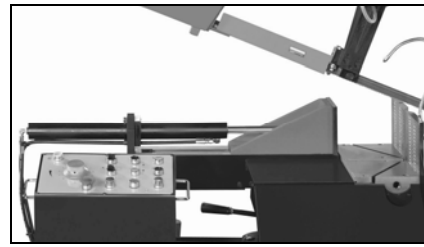

Adjusting the hydraulic vise for angle cutting

- The saw bow must be raised to clear the vise.

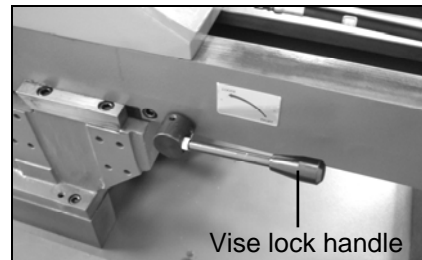

- Unlock the hydraulic vise lock handle.
- Push the hydraulic vise toward other side.
- Visually check clearance of the blade and saw bow against the hydraulic vise. Readjust the position if necessary.
- Lock the hydraulic vise in position using its lock handle.

5.3 Angle cutting

The machine can cut angles up to 60° in both directions

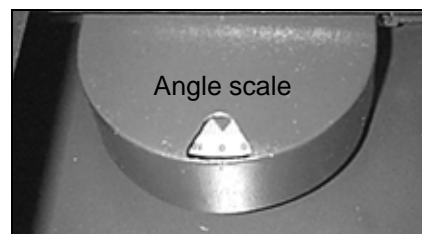
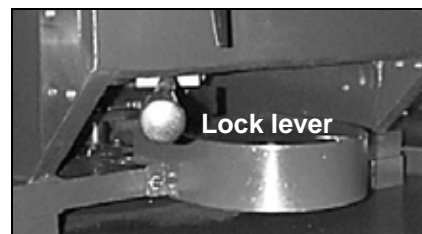

- Check that the saw bow is raised to clear the vise fixed vise jaw.
- Turn off power.
- Unlock the saw bow by using the lock lever under the machine bench.
- Rotate the saw bow to the desired cutting angle. Refer to the scale to determine the proper angle.
- Lock the cutting angle in place by using the lock lever.
- Next, adjust the location of the vise to avoid contact with the blade.

5.4 Using the vise

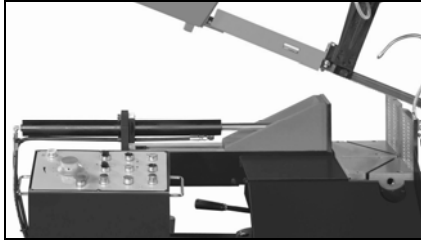

The hydraulic vise operates automatically and can be controlled using the control panel. Use the vise open button 3.1 J and vise close button 3.1 I to open and close the vise. Power must be active. Hydraulics must be active.

5.5 Adjusting the blade speed

- * Blade speed must be changed while belt and blade are moving.
- Check that the machine is running and blade is moving.
- Rotate the speed change dial 3.9 and check the speed scale for desired speed. Turn the dial counter clockwise to raise blade speed, and turn the dial clockwise to reduce blade speed. The speeds available are 32~96MPM (105~315FPM). If need to know real blade speed, it needs to measure with blade speed meter.



5.6 Changing the transmission belt

Over time and due to normal wear and tear the pulley belt will need to be changed.

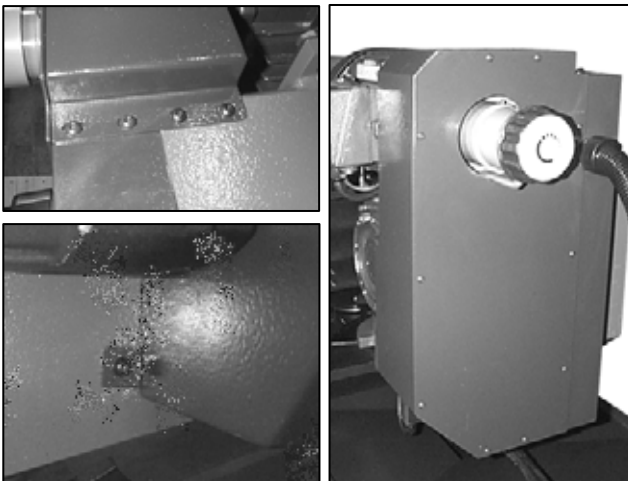

- Disconnect the machine from power supply.
- Open the belt cover. Remove 4 screws from the top. Remove 1 screw from the front. Remove 8 screws from the cover.
- Turn the dial counter-clockwise to open the pulley discs and loosen the belt.
- Replace the belt.
- Turn the dial to pretension the belt.

5.7 Changing the blade

⚠ WARNING
Disconnect the machine from the power source before making any adjustments or repairs! Failure to comply may result in serious injury!

- Raise the saw bow approximately 6" in height.
- Disconnect the machine from the power source.
- Remove both blade guides from the blade guide blocks and cover.
- Loosen the cover's lock screws and open the covers.
- Take off the chip brush device by loosen it's screws.
- Loosen left blade guide arm's lock handles and slides it to the right side as far as possible.
- Release blade tension by turning the blade tensioning handle counter-clockwise until blade is free.
- Remove the old blade from both wheels and out of each blade guide.

⚠ Caution: Even dull blades are sharp to the skin! Use extra caution handling band saw blades!

- Position the blade and making sure that the teeth are pointed downward in the cutting direction.
- Position the blade on the wheels. Make sure back of the blade rests lightly against the wheel flange of the both wheels. Twist blade slightly to allow it to slip into guides.
- Tension the blade to the tension indicator shown line 331DSA. Replace the chip brush device so that it touches the blade and tighten setscrew.



- Close all covers and guards and fasten securely. Connect machine to power and run the blade freely for 1-2 minutes.

- Turn the power off and recheck the blade tension and chip brush. If further adjustment is necessary disconnect the saw from the power source, make adjustments, and re-connect the power.

5.8 Laser guide device (optional)

The laser guide has been set correctly before shipment. The laser guide - line works when machine power on, the red line will align and close with the blade.

If any situations have to readjust Laser device, see below pictures.

- A screw for moving the device forward or backward.
- B screw for moving the device downward or upward.
- Loosen C thumb knob for adjust the device angle.

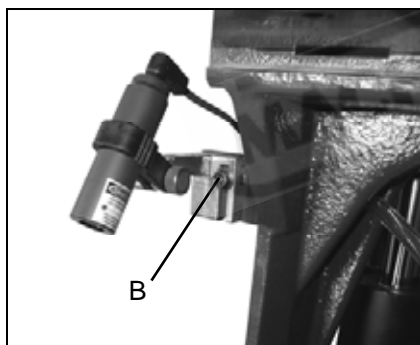
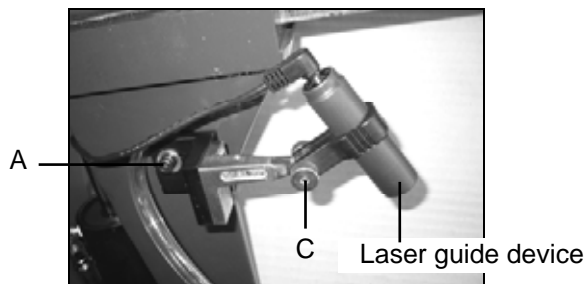

5.9 Install the vertical press on the vise jaws for bundle cutting (optional)

- Standard press capacity (W x H) 250~485 x 150~240 mm. Vise plates height 240 mm
- Special press capacity (W x H) 250~485 x 300~400 mm. Vise plates height 400 mm

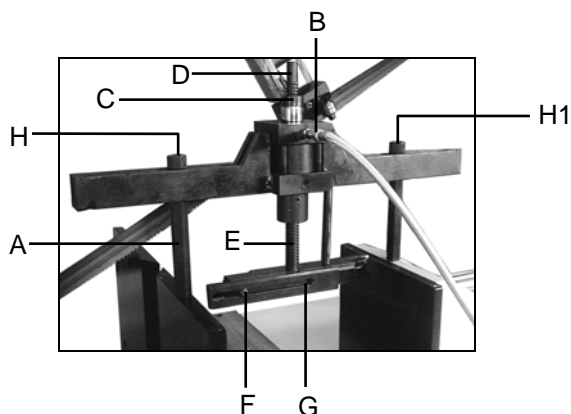

- Open the vise more than 250mm.
- Attach and Tighten posts bolts' (A) on to vises. Then attach the vertical press to the top of the post bolts. Connect the Hydraulic connector (B).
- Attach the nuts (H) on to the posts, but do not make the nut (H1) on moveable vise jaw too tight. *Otherwise, the vise won't be able to clamp the work piece or the post bolts will be damaged.
- Adjust the vise press (E) to sit approximately 5-8mm above the work piece. Loose nut (C) and rotate the bolt (D) to raise or lower the vise press (E).
- Adjust the vise press width to fit the work piece size. Loosen screws (F) on both sides of the vise press then move press extender bars (G) desired width.

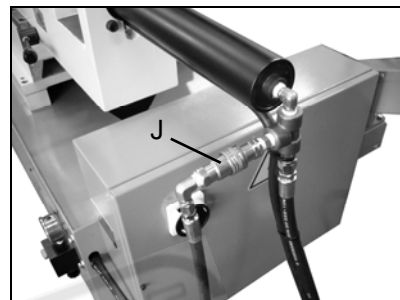

- Turn OFF the hydraulic pump.
- Attach the hydraulic hose to connector (B) and then attach the quick link connector (J) to the 90-degree fitting.
- Switch ON the hydraulic pump.

6 OPERATION CYCLE

6.1 Operation cycle

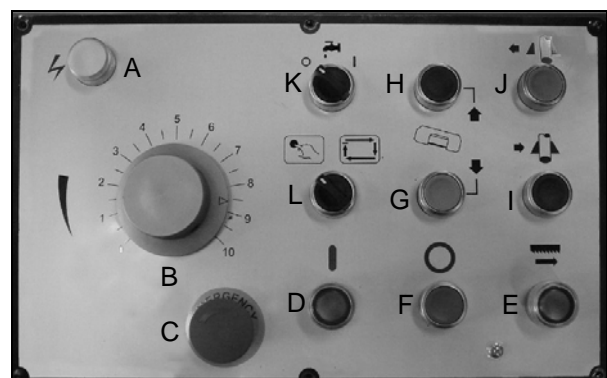

- Turn on the main connect. on the door of electrical box. Then the Power indicator (A) will light up.
- Start the hydraulic system, use button (D).
- Turn Switch (L) to Manual mode
- Raise the saw bow, Use bow up button (H).
- Open the vise, use vise open button (J)
- Load the working material.

- Secure the material, use the vise close button (I).
- Base on the diameter of the material; set the saw bow's height: contactor (5.1 L).
- Choose the blade speed appropriate for the material.
- Turn Switch (L) to Auto mode
- Start operation by using the start button (E)
- When the cutting operation is finished the saw bow will automatically rise to the preset height ready for the next operation.

6.2 Stopping or emergency stopping

There are two ways to stop the machine in an event of an emergency or improper operation.

- For most situations, use the stop switch 6.1 F
Using the stop switch 6.1 F will not reset the controls and your operation setting. The blade and drive motor will stop. Then the saw bow stay arise to the top position. open the vise to check the issue. After checking, close the vise and start to cutting
- For unsafe and emergency conditions use the emergency stop button 6.1 C. Using emergency stop button 6.1 C will stop the machine in last position. The motor and hydraulic will stop and control setting will be reset.
- To restart, the emergency stop button 6.1 C must be turned to release from the pressed position.

7 ROUTINE AND SPECIAL MAINTENANCE

The maintenance jobs are listed below, divided into daily, weekly, monthly and six-month intervals. If the following operations are neglected, the result will be premature wear of the machine and poor performance.

7.1 Daily maintenance

- Give general cleaning to the machine to remove accumulated shavings.
- Clean the lubricating coolant drain hole to avoid excess fluid.
- Top off the level of lubricating coolant.
- Check blade for wear.
- Rise of saw frame to top position and partial slackening of the blade to avoid useless yield stress.
- Check functionality of the shields and emergency stops.

7.2 Weekly maintenance

- Thoroughly clean the machine to remove shavings, especially from the coolant tank.
- Removal of pump from its housing, cleaning of the suction filter and suction zone.
- Clean the filter of the pump suction head and the suction area.

- Use compressed air to clean the blade guides (guide bearings and drain hole of the lubricating cooling).
- Clean flywheel housings and blade sliding surfaces on flywheels.

7.3 Monthly maintenance

- Check the tightening of the drive wheel screws.
- Check that the blade guide bearings on the heads are perfect running condition.
- Check the tightening of the screws of the motor, pump, and accident protection guarding.

7.4 Six-monthly maintenance

- Test the continuity of the equipotential protection circuit.

7.5 Oils for lubricating coolant

Considering the vast range of products on the market, the user can choose the one most suited to their own requirements, using as reference the type SHELL LUTEM OIL ECO. THE MINIMUM PERCENTAGE OF OIL DILUTED IN WATER IS 8 - 10 %.

7.6 Oil disposal

The disposal of these products is controlled by strict regulations. Please see the Chapter on "Machine dimensions Transport - Installation" in the section on Dismantling.

7.7 Special maintenance

Special maintenance must be conducted by skilled personnel. We advise contacting your nearest dealer and/or importer. Other protective and safety equipment, devices (of the reducer), the motor, the motor pump, and other electrical components also require special maintenance.

7.8 Changing gear oil

The gear box requires periodic changing of oil. The oil must be changed by the first 6 months of a new machine and every year thereafter.

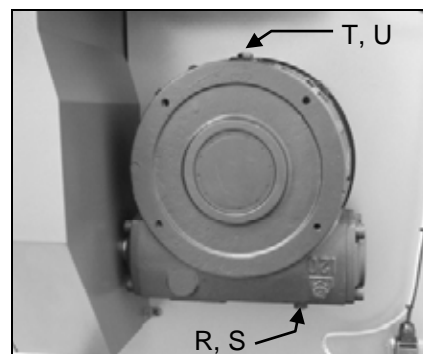



- To change the gear box oil
- Lower the saw bow to horizontal position.
- Disconnect the machine from the power source.
- Release the drain hold (R) to draw off gear oil by loosening the hex head screw (S).
- Open fill hole (T) by releasing hex head screw (U)

- Replace the screw (S) after oil completely flows off.
- Filling in gear oil from T hole, until oil be sight from the visual glass.
- Replace hole using the fill hole (T).
- Replace hex head screw (U).

8 TECHNICAL CHARACTERISTICS

8.1 Table of cutting capacity and technical details

Cutting Capacity			
90°	331mm(13")	320x485mm(12.6"x19.1")	260x510mm(10.23"x20.07")
45°	315mm(12.4")	315x315mm(12.4"x12.4")	
60°	215mm(8.46")	195x315mm(7.67"x12.4")	

Electric motor-blade rotation	3 HP (2.2 kW)
Blade size	34 x 1.1 x 4180 mm (1.3" x 0.043" x 164.5")
Blade speed cutting	50Hz 26 ~ 80 MPM (85 ~ 262 FPM) 60Hz 32 ~ 96 MPM (105 ~ 315 FPM)
Coolant tank volume	52 L
Hydraulic tank volume	12 L
Packing size	2310 x 1060 x 1500 mm (91" x 41.7" x 59")
Machine weight	835 kgs (1840 lbs)

TYPES OF STEEL						CHARACTERISTICS		
USE	I UNI	D DIN	F AF NOR	GB SB	USA AISI-SAE	Hardness BRINELL HB	Hardness ROCKWELL HRB	R=N/mm ²
Construction steels	Fe360	St37	E24	----	----	116	67	360÷480
	Fe430	St44	E28	43	----	148	80	430÷560
	Fe510	St52	E36	50	----	180	88	510÷660
Carbon steels	C20	CK20	XC20	060 A 20	1020	198	93	540÷690
	C40	CK40	XC42H1	060 A 40	1040	198	93	700÷840
	C50	CK50	----	----	1050	202	94	760÷900
	C60	CK60	XC55	060 A 62	1060	202	94	830÷980
Spring steels	50CrV4	50CrV4	50CV4	735 A 50	6150	207	95	1140÷1330
	60SiCr8	60SiCr7	----	----	9262	224	98	1220÷1400
Alloyed steels for hardening and tempering and for nitriding	35CrMo4	34CrMo4	35CD4	708 A 37	4135	220	98	780÷930
	39NiCrMo4	36CrNiMo4	39NCD4	----	9840	228	99	880÷1080
	41CrAlMo7	41CrAlMo7	40CADG12	905 M 39	----	232	100	930÷1130
Alloyed casehardening steels	18NiCrMo7	----	20NCD7	En 325	4320	232	100	760÷1030
	20NiCrMo2	21NiCrMo2	20NCD2	805 H 20	4315	224	98	690÷980
Alloyed for bearings	100Cr6	100Cr6	100C6	534 A 99	52100	207	95	690÷980
Tool steel	52NiCrMoKU	56NiCrMoV7C100K	----	----	----	244	102	800÷1030
	C100KU	C100W1	----	BS 1	S-1	212	96	710÷980
	X210Cr13KU	X210Cr12	Z200C12	BD2-BD3	D6-D3	252	103	820÷1060
	58SiMo8KU	----	Y60SC7	----	S5	244	102	800÷1030
Stainless steels	X12Cr13	4001	----	----	410	202	94	670÷885
	X5CrNi1810	4301	Z5CN18.09	304 C 12	304	202	94	590÷685
	X8CrNi1910	----	----	----	----	202	94	540÷685
	X8CrNiMo1713	4401	Z6CDN17.12	316 S 16	316	202	94	490÷685
Copper alloys Special brass Bronze	Aluminium copper alloy G-CuAl11Fe4Ni4 UNI 5275					220	98	620÷685
	Special manganese/silicon brass G-CuZn36Si1Pb1 UNI5038					140	77	375÷440
	Manganese bronze SAE43 - SAE430					120	69	320÷410
	Phosphor bronze G-CuSn12 UNI 7013/2a					100	56,5	265÷314
Cast iron	Gray pig iron		G25			212	96	245
	Spheroidal graphite cast iron		GS600			232	100	600
	Malleable cast iron		W40-05			222	98	420

8.2 NOISE TESTS

The test was held under environmental noise levels of 65db. Noise measurements with the machine operating unload was 71db. Noise level during the cutting of mild carbon steel was 73db.

NOTE: with the machine operating, the noise level will vary according to the different materials being processed. The user must therefore assess the intensity and if necessary provide the operators with the necessary personal protection, as required by Law 277/1991

9 CONTROL CIRCUIT DIAGRAM

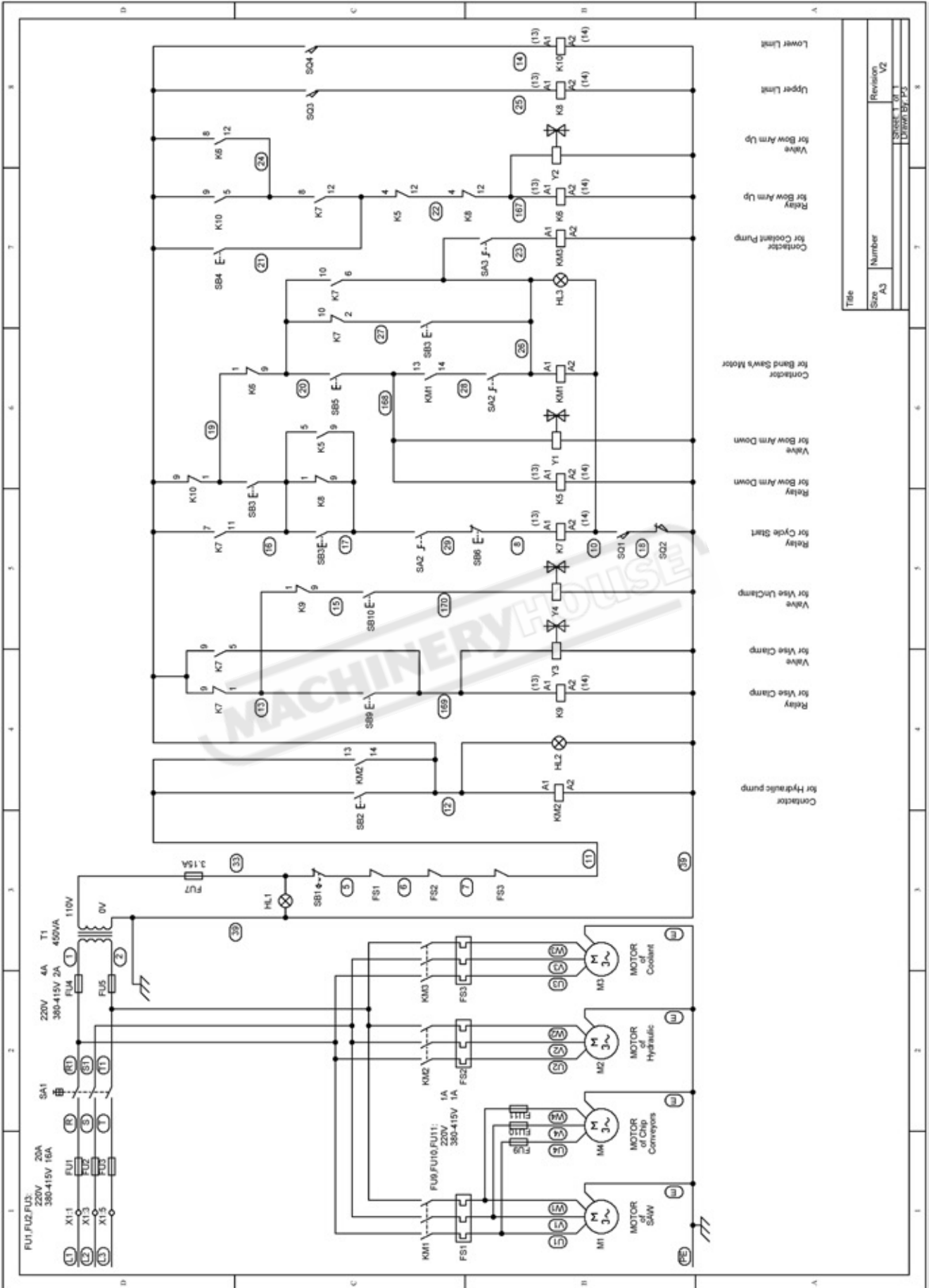

Title	
Size	Number
A3	
Revision	V2
Sheet	1 of 5
Drawn By	P5

SECTION A - PARTS LIST

Part No.	Description	Size / Stock No.	Q'ty	Part No.	Description	Size / Stock No.	Q'ty
A1	Hex. Cap Bolt	M8x20L	6	A48	Big Round Head Screw	M6x8L	6
A2	Coolant Tray	331D3-02	1	A49	Bracket Cover	331D3-36	1
A3	Hex. Cap Bolt	M8x16L	2	A50	Control Box	331D3-08-C	1
A4	Spring Washer	M8	2	A51	Round Head Screw	M5x8L	4
A5	Washer	M8	2	A52	Handle A-42-C	330S0418	2
A6	Hex. Cap Bolt	M8x16L	3	A53	Control Panel		1
A7	Spring Washer	M8	3	A54	Button Head Socket Screw	M5x8L	6
A8	Washer	M8	3	A55	Coolant Tray	331D3-02	1
A9	Lateral Plate	331D3-23-A	1	A56	Hex. Cap Bolt	M6x8L	2
A10	Hex. Cap Bolt	M12x20L	4	A57	Cover	331D3-49	1
A11	Spring Washer	M12	4	A58	Rear Cover	331D3-05-B	1
A12	Washer	M12	4	A59	Button Head Socket Screw	M6x8L	4
A13	Retrieval Table	331D3-23	1	A60	Fixed Bracket	331D3-02-B	6
A14	Base	331D3-01	1	A61	Nut	M8	12
A15	Washer	M8	12	A62	Spring Washer	M8	12
A16	Spring Washer	M8	12	A63	Washer	M8	12
A17	Hex. Cap Bolt	M8x20L	12	A64	Hex. Cap Bolt	M8x20L	6
A18	Hydraulic Unit		1	A65	Chip Tray	331D3-04	1
A19	Hex. Socket Cap Screw	M8x16L	2	A66	Hex. Cap Bolt	M6x12L	2
A20	Front Cover	331D3-05-A	1	A67	Washer	M6	2
A21	Hex. Socket Cap Screw	M6x8L	4	A68	Coolant Pump	1/6"x150L	1
A22	Nut	M12	4	A69	Pump Plate	331D3-39	1
A23	Hex. Cap Bolt	M12x70L	4	A70	Button Head Socket Screw	M6x12L	2
A24	Set Screw	M6x6L	4	A71	Pump Cover	331D3-05	1
A25	Hex. Socket Cap Screw	M6x12L	4	A72	Button Head Socket Screw	M6x8L	4
A26	Support Bracket	331D3-29-A	1	A73	Coolant Tray (Rear)	331D3-03	1
A27	Electrical Cabinet	331D3-06-E	1	A74	Washer	M8	2
A28	Cabinet Cover	331D3-07	1	A75	Spring Washer	M8	2
A29	Latch		2	A76	Hex. Socket Cap Screw	M8x16L	2
A30	Hex. Socket Cap Screw	M6x30L	1				
A31	Spring Washer	M6	1				
A32	Washer	M6	1				
A33	Button Head Socket Screw	M6x16L	4				
A34	Washer	M6	4				
A35	Connect Base	331D3-37	1				
A36	Hex. Cap Bolt	M8x16L	4				
A37	Spring Washer	M8	4				
A38	Swiveling Base	331D1-18-A	1				
A39	Lock Handle M8x30L	331D4-38	1				
A40	Spring Washer	M8	4				
A41	Hex. Cap Bolt	M8x16L	4				
A42	Nut	M8	2				
A43	Set Screw	M8x20L	2				
A44	Hex. Socket Cap Screw	M6x16L	4				
A45	Swiveling Bracket	331D1-18	1				
A46	Button Head Socket Screw	M6x8L	4				
A47	Control Box Bracket	331D3-35	1				

SECTION A

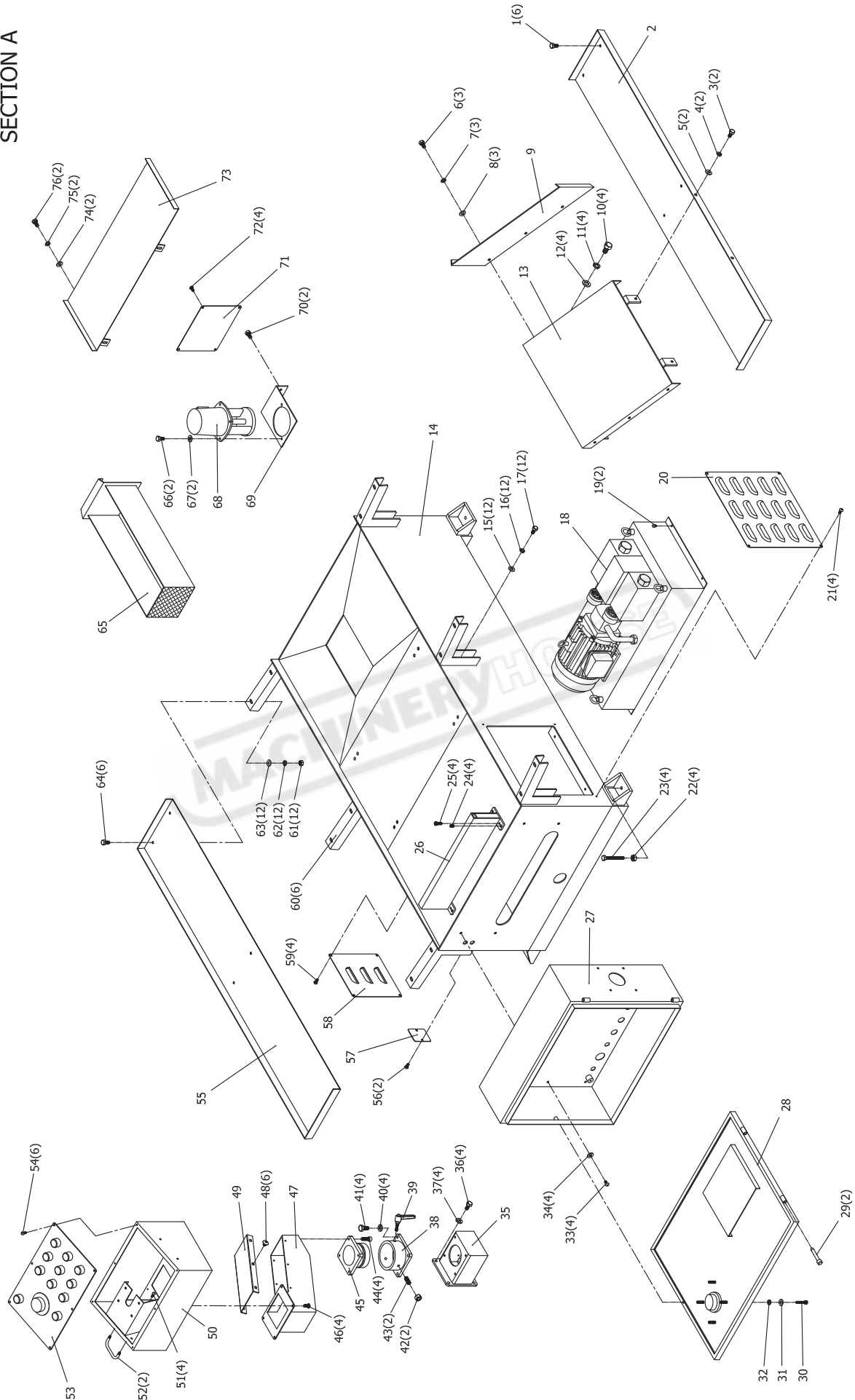

1021030-VI

SECTION B - PARTS LIST

Part No.	Description	Size / Stock No.	Q'ty	Part No.	Description	Size / Stock No.	Q'ty
B1	Lower Cover	331D3-26-A	1	B48	Hex. Socket Cap Screw	M8x20L	8
B2	Button Head Socket Screw	M5x8L	4	B49	Hex. Cap Bolt	M5x15L	1
B3	Cam Shaft	331D2-31	1	B50	Wire Fastener	331D2-35	1
B4	Bearing 6000	331D5-10A	1	B51	Angle Plate	331D2-25	1
B5	Spring Washer	M10	1	B52	Lower Cover	331D2-05	1
B6	Nut	M10	1	B53	Swiveling Seat	331D1-06	1
B7	Cam Bracket	331D2-30	1	B54	Swiveling Shaft	331D2-03	1
B8	Hex. Socket Cap Screw	M8x25L	2	B55	Bearing 30312	331D5-12	2
B9	C Ring	S16	1	B56	Cover	331D2-06	1
B10	Hex. Socket Cap Screw	M10x40L	1	B57	Set Screw	M6x25L	1
B11	Cam Spring	331D4-02	1	B58	Hex. Socket Cap Screw	M8x20L	8
B12	Nut	M10	1	B59	Tighten Plate	331D2-06-A	1
B13	Connect Plate	331D2-32	1	B60	O Ring	P60	2
B14	Locking Bolt	331D2-27	1	B61	Hex. Cap Bolt	M20x65L	1
B15	Hex. Socket Cap Screw	M10x50L	1	B62	Nut	M20	1
B16	Connect Block	331D2-28	1	B63	Hex. Cap Bolt	M10x60L	1
B17	Handle Shaft	331D2-29	1	B64	Nut	M10	1
B18	Nut	M12	1	B65	Upper Limit Position Screw	S20A2-01	1
B19	Handle	9160501	1	B66	Contact Plate	S20A3-09	1
B20	Angle Setting Block	331D2-26	1	B67	Washer	S138F2-26-A	1
B21	Hex. Socket Cap Screw	M8x20L	2	B68	POM Washer	S138F2-26-B	1
B22	Brake Bracket	331D1-11	1	B69	Nylon Nut	M10	1
B23	Button Head Socket Screw	M6x8L	2	B70	Hose SP105 1/4"x18"	L25A4-14	1
B24	Hex. Socket Cap Screw	M4x6L	2	B71	Swing Screw	M6x30L	2
B25	Magnifier Holder	331D3-43	1	B72	Hose Seat	L46N2-20	1
B26	Angle Magnifier	331D4-09	1	B73	Coolant Switch 1/4x1/4	L25A4-49	1
B27	Cover	331D3-25	1	B74	Hex. Socket Cap Screw	M10x30L	8
B28	Hex. Socket Cap Screw	M10x40L	1	B75	Right Laternal Plate	331D2-24	1
B29	Washer	M10	1	B76	Left Laternal Plate	331D2-23	1
B30	Central Wheel	331D2-33	1	B77	Screw Holder	1/2"	1
B31	Wire Fastener	331D2-35	1	B78	Lower Bracket	331D1-17	1
B32	Hex. Cap Bolt	M5x15L	1	B79	Spring Washer	1/2"	1
B33	Bush	331D2-34	1	B80	Nut	1/2"	1
B34	Steel Rope		1	B81	Spring Washer	M8	4
B35	Extend Spring	331D4-03	1	B82	Hex. Socket Cap Screw	M8x25L	4
B36	Pad	331D2-50	2	B83	Hex. Socket Cap Screw	M8x20L	2
B37	Spring Pin	8x20L	4	B84	Hex. Socket Cap Screw	M8x55L	2
B38	Hex. Socket Cap Screw	M12x70L	4	B85	Cutting Plate	331D1-03	1
B39	Set Screw	M12x30L	4	B86	Hex. Socket Cap Screw	M10x60L	2
B40	Cutting Base	331D1-01	1	B87	Spring Pin	8x20L	2
B41	Fixing Block	331D2-04	2	B88	Cutting Table	331D1-02	1
B42	Hex. Socket Cap Screw	M10x35L	4	B89	Vise Table	331D1-04-A	1
B43	Hex. Socket Cap Screw	M10x40L	1	B90	Spring Pin	8x20L	2
B44	Nut	M10	1	B91	Position Plate	331D2-61	1
B45	Spring Pin	8x20L	2	B92	Hex. Socket Cap Screw	M10x40L	4
B46	Hex. Socket Cap Screw	M10x25L	5	B93	Hex. Socket Cap Screw	M12x25L	4
B47	Spring Washer	M10	5	B94	Long Handle	331D4-26	1

SECTION B

1021030-VI

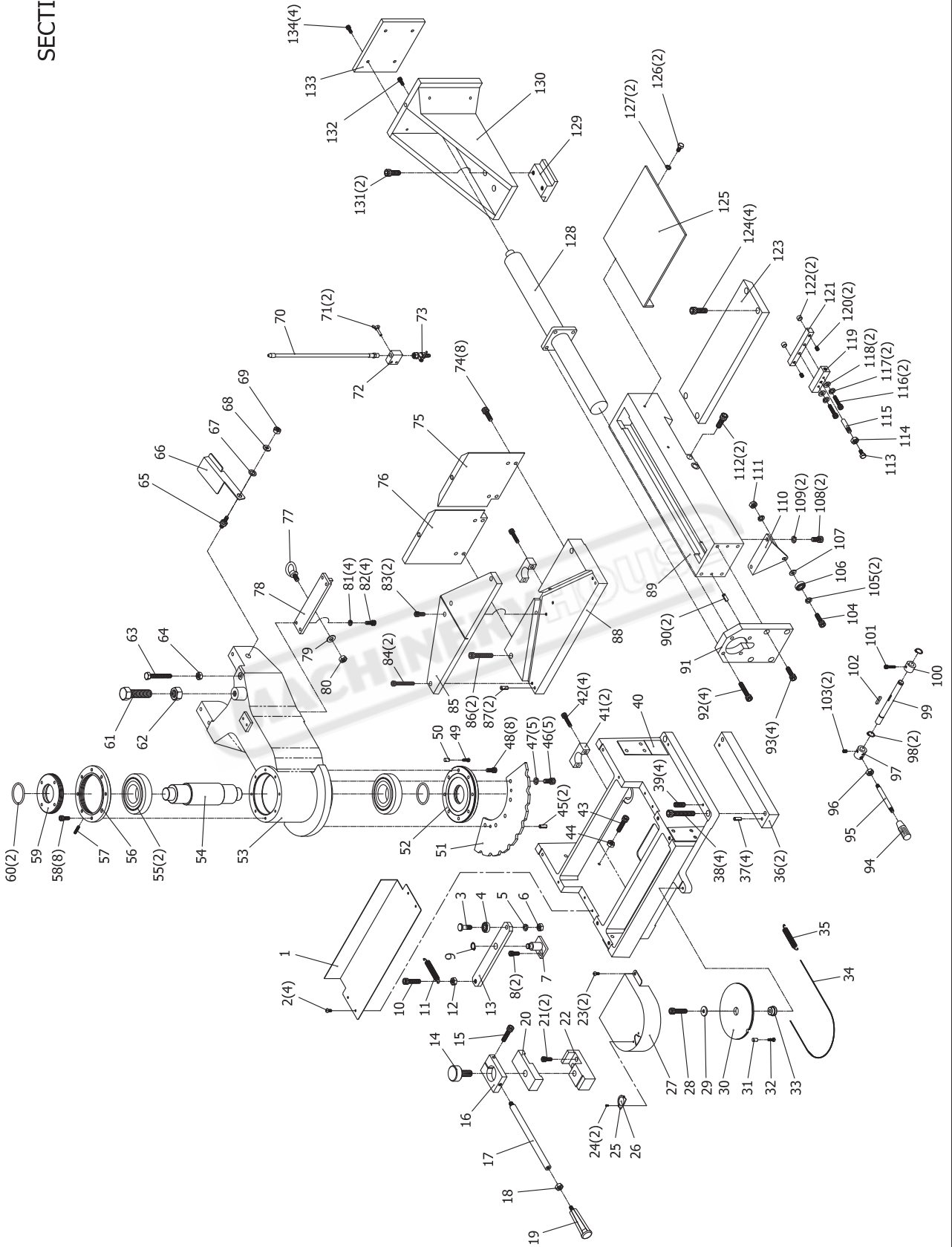

SECTION C - PARTS LIST

Part No.	Description	Size / Stock No.	Q'ty	Part No.	Description	Size / Stock No.	Q'ty
C1	Hex. Socket Cap Screw	M6x16L	1	C48	Contact Plate	331D2-48	1
C2	Spring Washer	M6	1	C49	Tension Gauge Spacer	331D2-16-A	1
C3	Shaft Bush	331D2-42-A	1	C50	Tension Gauge	331D5-00B	1
C4	Brush Drive Wheel	331D2-42	1	C51	Thrust Bearing 51203	331D4-18	1
C5	Shaft Bush	331D2-42-A	1	C52	Set Screw	M8x10L	1
C6	Set Screw	M6x6L	3	C53	Handle	W27D0245	2
C7	Position Bush	331D2-41	2	C54	Nut	M16	2
C8	Brush Shaft	331D2-40	1	C55	Handle Wheel	W27D0259	1
C9	Brush Position Bracket	331D3-17	1	C56	Thread Rod	M16	1
C10	Shaft	331D2-43	1	C57	Washer	331D2-12-C	1
C11	Hex. Socket Cap Screw	M8x45L	1	C58	C Ring	S35	2
C12	Hex. Socket Cap Screw	M6x8L	2	C59	Slide Block	331D2-13	1
C13	Shaft Tube	331D2-39	1	C60	Oil Nipple		1
C14	Brush 3"x6.35mm	331D4-08	1	C61	Idle Wheel Shaft Set	331D2-12	1
C15	Spring Washer	M6	1	C62	Set Screw	M12x25L	1
C16	Nut	M6	1	C63	Button Head Socket Screw	M5x8L	4
C17	Saw Frame	331D3-10	1	C64	Idle Wheel Cover	331D3-11	1
C18	Spring Washer	M10	4	C65	Hex. Socket Cap Screw	M10x55L	6
C19	Hex. Cap Bolt	M10x40L	4	C66	Spring Washer	M10	6
C20	Drive Wheel	331D1-13	1	C67	Slide Plate	331D2-15	2
C21	Washer	331D2-49	1	C68	Slide Guide	331D2-14	2
C22	Flat Head Screw	M12x25L	1	C69	Hex. Socket Cap Screw	M4x35L	2
C23	Button Head Socket Screw	M6x12L	2	C70	Steel Pin	14x70L	1
C24	Flat Head Screw	M4x10L	2	C71	Limit Switch AZD-S11	331D5-07	1
C25	Copper Lock	330S0419	1	C72	Limit Switch AZD-1001T	331D5-06	1
C26	Frame Cover Locker	331D3-27	1	C73	Hex. Socket Cap Screw	M4x35L	2
C27	Press Plate (POM)	331D2-55	1	C74	Eye Bearing		1
C28	Hex. Socket Cap Screw	M8x40L	2	C75	Hydraulic Cylinder		1
C29	Button Head Socket Screw	M6x20L	4	C76	C Ring	S16	2
C30	Fixing Block	331D2-44	2	C77	Lower Bracket	331D2-36	1
C31	Pin	14x70L	2	C78	Lower Bracket Shaft	331D2-37	1
C32	Brush Protect Bracket	331D3-14	1	C79	Hex. Socket Cap Screw	M8x20L	2
C33	Button Head Socket Screw	M5x8L	2	C80	Cylinder Support Rod	331D2-38	1
C34	Copper Lock	330S0419	1	C81	C Ring	S16	2
C35	Flat Head Screw	M4x10L	2	C82	Limit Switch AZD-1001T	331D5-06	1
C36	Cover Lock	331D2-45	2	C83	Hex. Socket Cap Screw	M4x35L	2
C37	Button Head Socket Screw	M6x12L	4	C84	Washer	331D2-01-A	1
C38	Frame Cover	331D3-10-A	1	C85	Oilless Bush 4040	331D5-14	2
C39	Button Head Socket Screw	M5x8L	2	C86	Bush Seat	331D2-02-A	2
C40	Shaft Nut	AN07(M35)	1	C87	Gear Reducer	331D4-07	1
C41	Teeth Washer	AW07(M35)	1	C88	Hex. Socket Cap Screw	M12x65L	4
C42	Shaft Cover	331D4-51	2	C89	Key	12x8x50	1
C43	Idle Wheel	331D1-12	1	C90	Hex. Socket Cap Screw	M4x35L	2
C44	Bearing 32007	331D5-13A	2	C91	Limit Switch ED1-3-32	H33D4-11	1
C45	Hex. Cap Bolt	M8x60L	1	C92	Button Head Socket Screw	M5x8L	2
C46	Nut	M8	1	C93	Speed Readout Frame	331D3-18	1
C47	Disc Spring 502225	460D4-09	8	C94	Laternal Plate	331D3-15-A	1

SECTION C - PARTS LIST

Part No.	Description	Size / Stock No.	Q'ty	Part No.	Description	Size / Stock No.	Q'ty
C95	Button Head Socket Screw	M5x8L	3	C142	Bearing 6000	331D5-10A	1
C96	Motor	3HP	1	C143	Adjusting Carbide (No Grooved)	331D2-09-A	1
C97	Key	10x8x40	1	C144	Fixed Carbide (No Grooved)	331D2-08-A	1
C98	Pulley Box	331D3-15	1	C145	Blade Guide Block (Rear)	331D1-10	1
C99	Button Head Socket Screw	M5x8L	5	C146	Hex. Socket Cap Screw	M6x16L	1
C100	Variable Speed Belt 1922V433	331D4-06	1	C147	Set Screw	M12x10L	1
C101	Variable Speed (Adjustable)	331D4-05	1	C148	Guide Post (Front)	331D1-07	1
C102	Cover	331D3-16	1	C149	Lock Handle M8x30L	331D4-38	2
C103	Seal Plate	331D3-16-A	1	C150	Hex. Socket Cap Screw	M8x25L	2
C104	Button Head Socket Screw	M5x8L	4	C151	Set Screw	M8x16L	3
C105	Button Head Socket Screw	M5x8L	6	C152	Adjusting Screw	3300209	1
C106	Hex. Socket Cap Screw	M8x65L	1	C153	Adjusting Spring	3300405	1
C107	Variable Speed (Fix)	331D4-05	1	C154	Pin	331D2-59	1
C108	Washer	M8	4	C155	Bearing 6000	331D5-10A	1
C109	Spring Washer	M8	4	C156	Adjusting Carbide (Grooved)	331D2-09	1
C110	Hex. Cap Bolt	M8x30L	4	C157	Fixed Carbide (Grooved)	331D2-08	1
C111	Nut	1/2"	2	C158	Bearing Shaft (Short)	331D2-10-A	1
C112	Spring Washer	1/2"	2	C159	Bearing Shaft (Long)	331D2-10	1
C113	Upper Bracket	S20A1-03	1	C160	Set Screw	M12x10L	1
C114	Spring Washer	M10	2	C161	Hex. Socket Cap Screw	M6x16L	1
C115	Hex. Socket Cap Screw	M10x25L	2	C162	Balde Guide Block (Front)	331D1-09	1
C116	Spring	331D4-01-A	1	C163	Shaft Washer	331D2-10-C	1
C117	Button Head Socket Screw	M5x8L	2	C164	Shaft Bush	331D2-10-B	1
C118	Blade Protector	331D3-48-B	1	C165	Bearing 6200	L25A5-01	2
C119	Blade Protector	331D3-48-A	1	C166	Spring Washer	M10	2
C120	Button Head Socket Screw	M5x8L	1	C167	Nut	M10	2
C121	Spring Pin	4x12L	1	C168	Blade Protector	331D3-12-A	1
C122	Set Screw	M10x16L	10	C169	Button Head Socket Screw	M5x8L	2
C123	Plate	331D2-07-A	2				
C124	Guide Plate	331D2-07	1				
C125	Hex. Socket Cap Screw	M10x20L	10				
C126	Bearing Shaft (Long)	331D2-10	1				
C127	Bearing Shaft (Short)	331D2-10-A	1				
C128	Guide Post (Rear)	331D1-08	1				
C129	Hex. Socket Cap Screw	M8x30L	2				
C130	Button Head Socket Screw	M6x8L	2				
C131	Position Bracket	331D3-22	1				
C132	Hex. Socket Cap Screw	M8x25L	2				
C133	Set Screw	M8x16L	3				
C134	Adjusting Screw	3300209	1				
C135	Adjusting Spring	3300405	1				
C136	Pin	331D2-59	1				
C137	Shaft Washer	331D2-10-C	1				
C138	Nut	M10	2				
C139	Spring Washer	M10	2				
C140	Bearing 6200	L25A5-01	2				
C141	Shaft Bush	331D2-10-B	1				

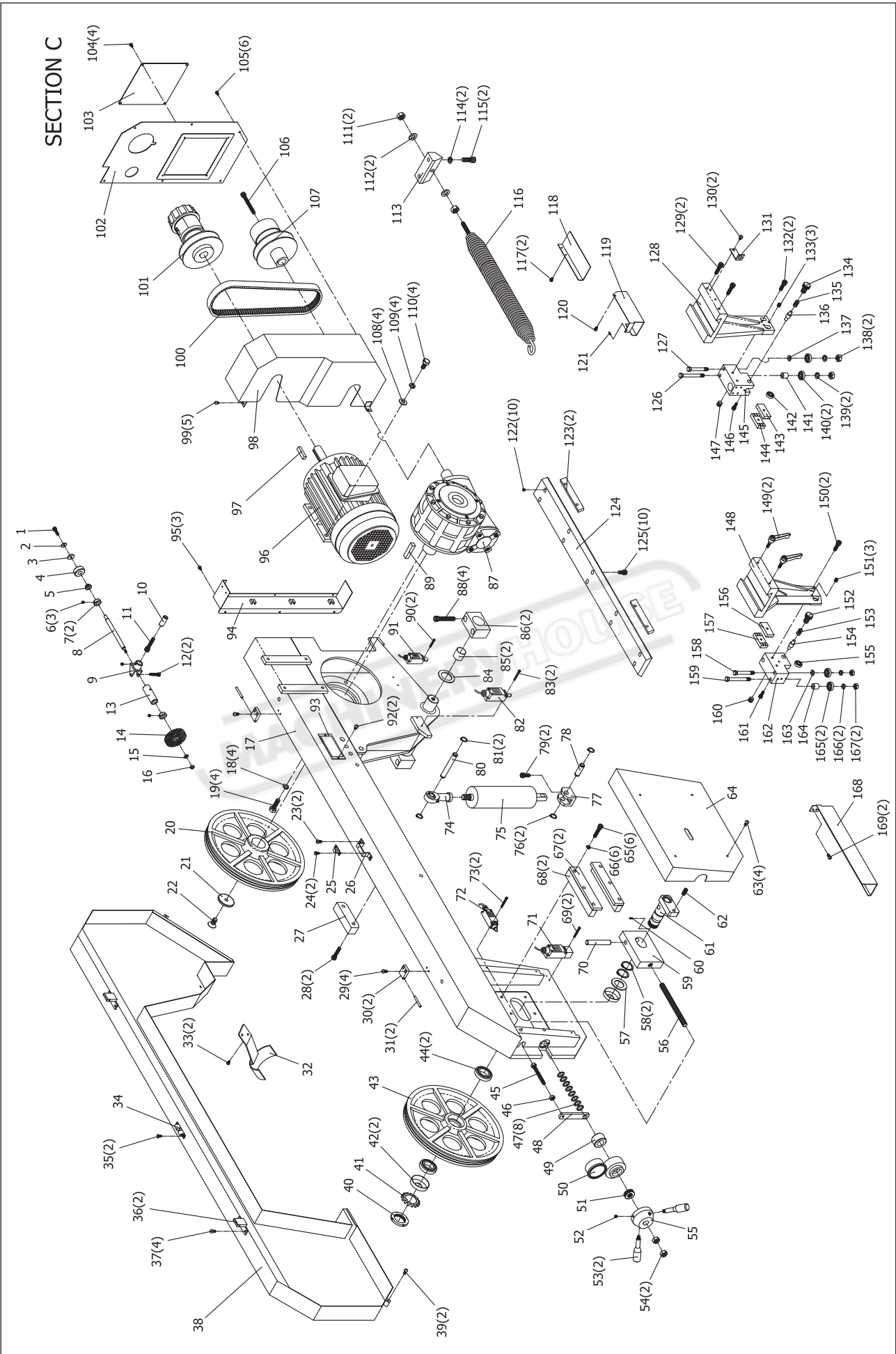

1021030-VI

SECTION D - PARTS LIST

Part No.	Description	Size / Stock No.	Q'ty	Part No.	Description	Size / Stock No.	Q'ty
D1	Power Switch		1	D48	Operation Mode Switch		1
D2	Coolant Overload Relay		1				
D3	Coolant Contactor		1				
D4	Hydraulic Motor Overload Relay		1				
D5	Hydraulic Motor Contactor		1				
D6	Blade Motor Overload Relay		1				
D7	Blade Motor Contactor		1				
D8	Transformer Power in Fuse		1				
D9	Transformer Power in Fuse		1				
D10	Transformer Output Fuse AC110V		1				
D11	Transformer Output Fuse AC110V		1				
D12	Transformer		1				
D13	Terminal Board		1				
D14	Relay Base		1				
D15	Relay		1				
D16	Relay Base		1				
D17	Relay		1				
D18	Relay Base		1				
D19	Relay		1				
D20	Relay Base		1				
D21	Relay		1				
D22	Relay Base		1				
D23	Relay		1				
D24	Relay Base		1				
D25	Relay		1				
D26	Brush Motor Fuse		1				
D27	Brush Motor Fuse		1				
D28	Brush Motor Fuse		1				
D29	Terminal Board		1				
D30	Power in Fuse		1				
D31	Power in Fuse		1				
D32	Power in Fuse		1				
D33	Power in Terminal Board		1				
D34	Power in Terminal Board		1				
D35	Power in Terminal Board		1				
D36	Grounding Plate		1				
D37	Power Indicator Light		1				
D38	Blade Stop Button		1				
D39	Coolant ON/OFF Switch		1				
D40	Saw Frame Decend Button		1				
D41	Saw Frame Lift Button		1				
D42	Vise Open Button		1				
D43	Vise Close Button		1				
D44	Blade Start Button		1				
D45	Hydraulic Power Button		1				
D46	Emergency Stop Button		1				
D47	Down Speed Flow Valve		1				

SECTION D

